

Operator's Manual



DLS-2A

Diver's Locator Sonar

Non-Magnetic



Ultra Electronics Ocean Systems

115 Bay State Drive

Braintree, MA 02184

TEL: (781) 848-3400

FAX: (781) 843-2153

WEB: <http://www.ultra-os.com>

Table of Contents

Operator's	1
Manual	1
Foreword	1
Warranty	1
Liability	1
Changes	1
Safety Summary	2
General Information	3
General Description	3
Modes of Operation	4
Active Mode	4
Passive Mode	4
Sonar Set Components	5
Sonar Unit	7
Operation	8
Instructions	8
Operating Modes	9
Operating the Sonar Unit in Active Mode	9
Operating the Sonar Unit in Passive Mode	9
Procedures	9
Operational Readiness Check	10
Pre-Deployment Check	11
Post-Operation and Corrective Maintenance Procedures	12
Scheduled Maintenance	14
Theory of Operation	15
Purpose	15
Active Mode	15
Passive Mode	15
Other Functions	16
Functional Block Diagram	16
Accessories	17
Index	1

**Table of
Contents**
Continued

List of Illustrations

Figure 1 – Sonar Unit 3
Figure 2 – Sonar Set Components 5
Figure 3 – Sonar Unit Operator Controls 8
Figure 4 – DLS-2A Sonar Unit Functional Block Diagram 16
Figure 5 - Sonar Set Accessories 17

List of Tables

Table 1 – Physical and Functional Characteristics of the Sonar Unit 7
Table 2 – Sonar Unit Controls and Indicators 8
Table 3 – Sonar Unit Scheduled Maintenance 14
Table 4 – Sonar Set Accessories 17

Foreword

This manual provides information about and operating instructions for the DLS-2A (Diver's Locator Sonar) Hand-Held Sonar Set. It is recommended that you store this document with the DLS-2A in the accompanying carrying case.

The information, descriptions, photographs, and illustrations in this manual are the property of Ultra Electronics Ocean Systems. Material from this manual may not be reproduced or disseminated without the prior written consent of Ultra Electronics Ocean Systems.

Requests for additional copies of this manual should be submitted to Ultra Electronics Ocean Systems, 115 Bay State Drive, Braintree, MA 02184.
Telephone (781) 848-3400 • *Fax* (781) 843-2153.

Warranty

Ultra Electronics Ocean Systems warrants all of its products to be free from defects in material and workmanship for a period of one year from date of delivery to the original purchaser. Obligation under this warranty is limited to the repair or, at the sole discretion of Ultra Electronics Ocean Systems, replacement of any product returned to Ultra Electronics Ocean Systems.

Liability

Ultra Electronics Ocean Systems assumes no liability for damages, losses, or costs incurred consequentially through operation or malfunction of Ultra Electronics Ocean Systems.

Changes

Ultra Electronics Ocean Systems reserves the right to make changes to design or specifications at any time without incurring any obligation to modify previously delivered units.

This manual is provided for informational and reference purposes only, and is subject to change without notice.

Safety Summary

The following are general safety precautions related to specific procedures. These precautions also appear in this publication on the indicated page numbers. The recommended precautions should be understood by personnel and applied during various operations and maintenance phases.

On page 15:

WARNING

In order to ensure the safety of the diver, it is paramount that the Sonar System be re-certified for Low Magnetic Signature every 36 months

On page 6 and 11:

WARNING

The removable compass is magnetic. The compass is not to be used on magnetic-influence-type recovery missions.

On page 11:

CAUTION

Should the sonar unit become flooded, remove both bulkheads carefully. Wash out both sections of the unit several times using fresh water. Replace the bulkheads when the unit is thoroughly dry. No further maintenance is to be performed by the customer; return the unit to Ultra Electronics Ocean Systems for further evaluation and repair.

On page 12:

CAUTION

Use only water and a mild detergent to clean the sonar unit's housing and handle. After each use, visually inspect all external surfaces for damage that may cause internal problems.

On page 13:

CAUTION

Use care when removing the battery vent plug; gas build-up may cause elevated pressure in the front compartment.

General Information

General Description

The DLS-2A Sonar Set is a portable, self-contained, non-magnetic sonar system designed for use by underwater divers in locating submerged objects. The sonar unit, shown in Figure 1, is the major operating component of the DLS-2A Sonar Set. This compact, light-weight unit can be operated by a diver using one hand. A pole-mount interface is available as an option for over-the-side operations aboard ships and small launches.

The unit functions to depths of 91 meters (300 feet) and has an operating range in excess of 2000 meters (2180 yards). It has both active and passive modes of detection for detecting objects and pingers.

For details on the operation of the DLS-2A, refer to the section, "Theory of Operation," on page 15.

Read this manual to familiarize yourself with the proper use and operation of the sonar unit. **Note:** Maintenance of the unit by the customer should be limited to outer case cleaning and battery charging, whenever possible.



Figure 1 – Sonar Unit

General Information
(Continued)

The sonar unit is capable of two modes of operation: active and passive.

- In the **active mode**, the sonar unit provides both bearing and range information for a detected object using a continuous transmission of frequency modulated (CTFM) signals.
- The sonar unit employs a **passive mode** of operation for the location of pingers or marker beacons. In this mode, the sonar unit is capable of provided bearing information only.

Modes of Operation

Following is reference data for the active and passive modes of operation.

Active Mode

In the active mode of operation the sonar unit uses a swept frequency transmission technique. The bandwidth of the frequency sweep is 30 kHz and ranges from 145 kHz down to 115 kHz.

Three range scales (20, 60, or 120 yards) of linearly swept CTFM are available. The transmitted signal is reflected from an underwater object, received by the transducer, electronically processed, and then perceived in the headset as an audible tone in the 250 to 2500 Hz range.

Passive Mode

In the passive mode of operation, the DLS-2A operates as a pinger or marker beacon locator. In this receive-only mode, the unit converts pinger frequencies to audible tones in the diver's headphones. The wide bandwidth of the receiver (a characteristic of CTFM design) permits operation with pingers transmitting over a 24 to 45 kHz band.

The diver can tune the receiver to discriminate among several pingers. The DLS-2A is sensitive — it can locate a commonly-available type pinger, the 39 kHz, at more than 2000 meters (2180 yards) using an omni-directional pattern; 150 dB// μ Pa @ 1m.

General Information
(Continued)

Sonar Set Components

The components of the Sonar Set are shown in Figure 2 and described in this section.



A – Sonar Unit



D – Headset



G – Battery Charger



B – Carrying Case



E – Skull Cap



H – Flotation Collar



C – O-Ring Lubricant



F – Operator's Manual



I – Compass

Figure 2 – Sonar Set Components

General Information
(Continued)

The **sonar unit** (Figure 2-A) consists of a waterproof cylindrical housing, front and rear bulkheads, and a handle and lanyard assembly for handling and aiming the sonar. In active mode, it provides both bearing and range information for a detected object. In passive mode, it provides bearing information only, used to locate pingers or marker beacons. Refer to "Sonar Unit" on page 7 for a more detailed description.

The reinforced, padded **carrying case** (Figure 2-B) is used to house and transport the sonar unit (A) and the other ancillary equipment: the headset (D), skull cap (E), battery charger (G), flotation collar (H), compass (I), O-ring lubricant (C), and this manual (F).

The electrical **headset** (Figure 2-D), designed to conform to the **skull cap** (E), connects to the sonar unit through a waterproof connector on the rear bulkhead. **O-ring lubricant** (C) is applied to the plug on the headset cable prior to insertion in the connector. A diver can then use the headset to detect:

- a bearing by listening to the changes in the audible tone
- the signal from a pinger or marker beacon by listening for audible beat tones

The **battery charger** (Figure 2-G) operates on either 115 or 230 Vac to charge the batteries. The charger connects to the batteries through a connector located forward of the sonar unit handle. Refer to the section, "Charging the Batteries" on page 13, for important information on charging the batteries.

The **flotation collar** (Figure 2-H), provides positive buoyancy for the sonar unit, as required for training or other purposes.

The removable **compass** (Figure 2-I), which can be mounted on the flotation collar, assists the diver in recovery operations.

WARNING

The removable compass is magnetic. The compass is not to be used on magnetic-influence-type recovery missions.

General Information
(Continued)**Sonar Unit**

The sonar unit (Figure 1) consists of the following:

- **Housing**

The cylindrical housing for the sonar unit is constructed of polycarbonate plastic. A bulkhead divides the housing into two separate waterproof compartments. The front compartment contains two rechargeable, 6-volt Gel Cell batteries connected in series, as well as a receptacle for battery recharging. The rear compartment houses the sonar electronics.

- **Front bulkhead**

The front bulkhead contains the encapsulated transmit and receive transducers.

- **Rear bulkhead**

Controls mounted on the rear bulkhead of the sonar unit vary function switch and potentiometers through the use of coupling shafts. This bulkhead also mounts the waterproof headset connector.

- **Handle and lanyard**

These allow you to handle and aim the sonar unit.

Table 1 provides the physical and functional characteristics of the sonar unit.

Table 1 – Physical and Functional Characteristics of the Sonar Unit

Description	Data
Equipment Weight	
In Air	7.5 pounds ± 0.5 pounds (3.4 kg ± 0.2 kg)
Submerged (without the flotation collar)	10 ounces ± 2 ounces (0.3 kg ± 0.06 kg)
Environmental Limits	
Operating Temperature	0° C to 30° C
Operating Range	2180 yards (2000m) (in passive mode)
Maximum Operating Depth	300 ft. (91m)
Frequency Range	
Active Mode	145 kHz to 115 kHz
Passive Mode	24 to 45 kHz
Rechargeable Batteries	
Operating Time	10 hours
Charging Time	12 to 24 hours

Operation

Instructions

This section provides instructions for using sonar, preparing and testing the sonar unit prior to use, and operating the sonar unit.

Figure 3 shows the controls and indicators that are located on the rear bulkhead of the sonar unit; Table 2 lists their functions.

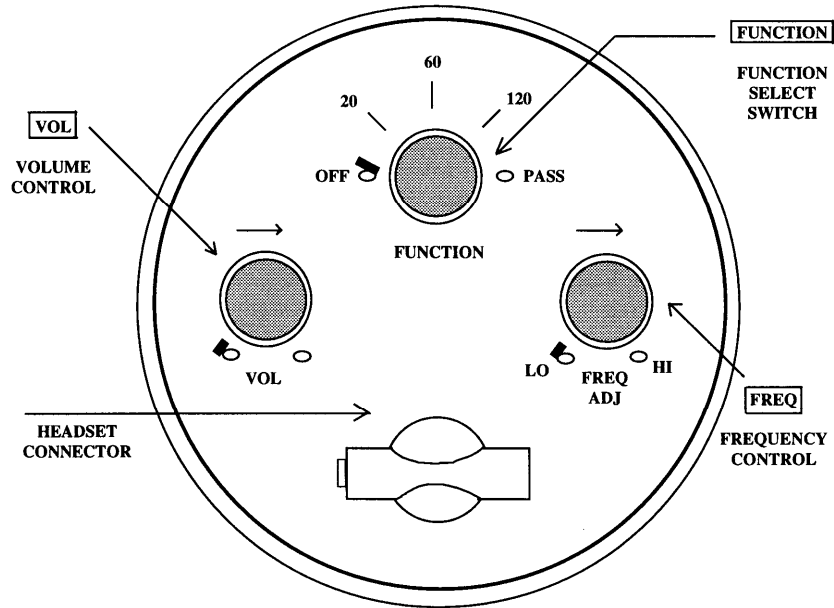

Figure 3 – Sonar Unit Operator Controls

Table 2 – Sonar Unit Controls and Indicators

Name	Reference Designation	Function
FUNCTION	S1	Power On/Off
Function Select Switch	5 position rotary switch	Active Mode select range scales of 20, 60, or 120 yards; Passive Mode selection
VOL Volume Control	R3 - 10K potentiometer	Increase Volume (CW) Decrease Volume (CCW)
FREQ ADJ Frequency Adjust Control	R2 - 1K potentiometer	Used in Passive Mode to obtain an audible beat tone with the received acoustic signal

Operation
(Continued)

Operating Modes

The sonar unit can operate in one of two modes: active or passive.

Operating the Sonar Unit in Active Mode

In the active mode of operation, the sonar unit transmits a narrow-beam ultrasonic wave that sweeps a specific bandwidth. The directionality of the beam provides you with angular sensing (bearing) of the target. The target echo, combined with a sample of the transmitted signal, produces an audible difference signal proportionate to the distance to the target. As you move closer to the target, the audible tone changes to a lower pitch to provide distance sensing (range) of the target.

Begin by searching in the longest range, 120 yards, and then reduce the range scale as you close in on the target. You will hear a 2500 Hz tone in your headset at the maximum range for the three range scales: 120, 60, and 20 yards. You normally switch to a lower setting when the audible tone decreases to less than 500 Hz.

Use the **FUNCTION** control (shown in Figure 3) to select the 20, 60, or 120 yard range scale. Use the **VOL** control to adjust the level of the headset tone.

Operating the Sonar Unit in Passive Mode

When you are using the sonar unit to locate a pinger or marker beacon, operate the sonar unit in passive mode.. In the passive mode, the sonar transmitter is disabled and the sonar unit functions as a receiver only. The sonar unit indicates direction (bearing) to the pinger or beacon and is capable of angular sensing (bearing detection) of pingers or beacons in the 24 to 45 kHz range.

Use the sonar unit controls (shown in Figure 3) as follows:

- **FUNCTION** to switch to passive mode
- **FREQ ADJ** to obtain an audible beat tone with the incoming pinger or marker beacon signal
- **VOL** to obtain a comfortable headset signal level as you approach the pinger or beacon

Procedures

This section provides step-by-step instructions for:

- preparing the sonar unit for use
- familiarizing yourself on the operation of the unit
- preventative and corrective maintenance

Operation
(Continued)

Operational Readiness Check

Prior to each use of the sonar unit, perform the following operational readiness check (ORC).

Visual Check

Visually check the equipment to ensure mechanical and watertight integrity and to determine that all controls operate freely without binding.

Battery Check

The sonar unit is powered by internal, rechargeable batteries that must be given a full, fresh charge prior to each use. Use the battery charger, stored in the carrying case, for this purpose. The battery charger operates on either 115 or 230 Vac. Full charging takes from 12 to 24 hours. **Note:** The batteries will *not* be damaged if the charger is left connected beyond the time it takes to fully charge the battery.

For information on how to charge the batteries, refer to page 13.

Air Test

You can operate the sonar unit out of water without damaging it. An air test is a good indicator of the sonar unit's performance in water.

Note: Due to the very narrow transmit beam in air, you need to keep the sonar unit pointed at the same spot on the wall throughout this test. It is recommended that you use a wheeled cart or table to support the sonar unit while conducting the air test.

To perform an air test:

1. Set the **FUNCTION** control, located on the sonar unit rear bulkhead, to the 60 yard range scale.
2. Set the **VOL** control to maximum level.
3. Place the sonar unit on a table or wheeled cart with the transducer pointed at, and 5 to 6 feet from, a hard-surfaced wall. Sound travels more slowly in air than in water; therefore, you should hear a signal (echo) from the wall in the headset at this distance.
4. Position the unit 10 to 12 feet from the wall and aimed at the same spot. If the unit is in satisfactory operating condition, you should detect a signal up to this distance before the signal becomes inaudible.

Operation
(Continued)

Pre-Deployment Check

If you are a first-time user of this sonar unit, take enough time to become familiar with the DLS-2A.

WARNING

The removable compass is magnetic. The compass is not to be used on magnetic-influence-type recovery missions.

Use the side of the boat as a target surface for this test. A successful test in the water will assure proper operation of the sonar unit.

CAUTION

Should the sonar unit become flooded, remove both bulkheads carefully. Wash out both sections of the unit several times using fresh water. Replace the bulkheads when the unit is thoroughly dry. No further maintenance is to be performed by the customer; return the unit to Ultra Electronics Ocean Systems for further evaluation and repair.

Pre-Deployment Steps

1. Place the electrical headset into the skull cap.
2. Lubricate the plug on the headset cable with the lubricant supplied with the sonar set.
3. Plug the headset cable into the waterproof connector mounted on the rear bulkhead of the sonar unit.
4. Put the skull cap on.
5. Set the **FUNCTION** control to 20 (active mode with a range of 20 yards).
6. Turn the **VOL** control counter-clockwise to the minimum volume setting.
7. Enter the water, and aim the sonar unit at the hull of your boat (your target surface for this test) from a distance of 4 to 6 feet.
8. Adjust the **VOL** control until the volume is at a comfortable level.
9. Aim the sonar unit away from the target surface and note that the audio signal increases in pitch. Experiment with the sonar unit, aiming it at different surfaces, and note the changes in the audio tone.

Operation
(Continued)*If the Unit Fails to Operate...*

Check the following:

- The electrical headset cable is securely connected to the sonar unit.
- The battery is fully charged.
- The sonar unit is aimed directly at a flat, hard surface during the test.
- The **FUNCTION** control is set to 20, and the **VOL** control is at a comfortable level.

If the unit still does not operate properly after you have checked all the items in the preceding list, contact Ultra Electronics Ocean Systems for technical assistance.

Post-Operation and Corrective Maintenance Procedures

As soon as possible after each use, follow these steps to assure continued reliable performance from the DLS-2A:

1. Turn the **FUNCTION** control to the **OFF** position.
2. Disconnect the headset from the sonar unit, and remove it from the skull cap.

CAUTION

Use only water and a mild detergent to clean the sonar unit's housing and handle. After each use, visually inspect all external surfaces for damage that may cause internal problems.

3. Wash all the components with fresh water and a mild detergent. Dry them thoroughly.
4. Lubricate the headset cable connector with a light coating of O-ring lubricant, supplied with the DLS-2A sonar set.
5. Check each item for signs of damage or wear.
6. Wash the sonar unit after each use, and be sure to remove any film build-up accumulating on the transducer on the front of the sonar unit.
7. Dry the unit thoroughly.
8. Recharge the battery following the procedure in the next section.
9. Return all components to the carrying case for storage.

Operation
(Continued)*Charging the Batteries***CAUTION**

Use care when removing the battery vent plug; gas build-up may cause elevated pressure in the front compartment.

To charge the batteries:

1. Ensure that the sonar unit is dry.
2. Remove the vent plug located just forward of the handle on the sonar unit.
3. Use the lubricant provided with the sonar unit to lubricate the O-ring seal. (Lubricate the O-ring each time you remove the plug.)
4. Connect the charger to the batteries through the charging receptacle in the sonar unit handle.

When connected, the red LED (light emitting diode) on the charger illuminates to indicate that charging current is being drawn. It will light briefly when a discharged battery is first connected. Very deeply discharged batteries will draw very little current initially and should be charged for 48 to 72 hours. **Note:** The batteries will *not* be damaged if the charger is left connected beyond the time it takes to fully charge the battery.

The LED does not instantaneously indicate battery condition. You can use a voltmeter to check battery charge at the charging receptacle. A freshly charged battery should read between 13.5 and 13.9 volts open circuit (sonar unit turned off). The sonar unit will operate with the battery reading as little as 9 or 10 volts. At this level, however, performance capability is degraded.

If the Unit Fails to Operate...

Follow these corrective measures:

- Check to ensure that the battery is fully charged. If the battery will not hold a charge, contact Ultra Electronics Ocean Systems for a replacement.
- Use the **FUNCTION** control to turn the sonar unit on and off several times to ensure that the switch is working properly.
- Make sure that the transducer head is clean and free of film build-up.
- Remove the rear bulkhead, and inspect for loose wires and connectors.
- If either bulkhead has been removed, clean and lubricate the O-ring grooves.
- Inspect and replace the vent plug O-ring.

If the preliminary troubleshooting does not resolve the problem, contact Ultra Electronics Ocean Systems for service and technical assistance.

Scheduled Maintenance

Scheduled maintenance for the DLS-2A is listed in Table 3 below.

Table 3 – Sonar Unit Scheduled Maintenance

Type of Maintenance	Period	Performed By
External Cleaning	After each use	The customer
Battery Charging	As required	The customer
Recertification for Non-Magnetic Signature Effect.	Every 36 months*	Ultra Electronics Ocean Systems

* Required

Theory of Operation

Purpose

The DLS-2A Sonar Set is a portable, self-contained non-magnetic sonar system designed for use by underwater divers in locating submerged objects. The sonar unit can operate in two modes: active and passive. The non-magnetic construction of the sonar unit permits its use in Explosive Ordnance Disposal operations.

. WARNING

In order to ensure the safety of the diver, it is paramount that the Sonar System be re-certified for Low Magnetic Signature every 36 months

Active Mode

A functional block diagram of the sonar unit is presented in Figure 4. In the active mode, a ramp generator produces a ramp waveform having a period determined by the range switch. The ramp is applied to a voltage-controlled oscillator (VCO), which results in a linear, downward sweeping, frequency modulated signal varying between 145 kHz and 115 kHz. The signal is amplified and drives the transmit transducer that produces a narrow beam conical wave. When the wave strikes an underwater object, the reflected signal is received by the sonar receive transducer, located in the front bulkhead.

The two-way, underwater path requires a finite time interval. Based on a nominal speed of sound in water of 4800 feet per second, the travel time to and from a target at 60 yards is 24 milliseconds. In this interval, the VCO frequency will decrease 2500 Hz on the 60-yard range scale.

A sample of the transmitted signal and the received echo are heterodyned in the mixer stage, with the 2.5 kHz difference signal filtered, amplified, and perceived through headphones by the operator as an audible tone. A lower 250-Hz tone would be heard by the operator had the target been a tenth of the distance away. With the sonar range set at 20 yards, the steeper ramp and faster sweep would result in a 750-Hz tone for the target at the same distance.

Passive Mode

With the sonar unit in the passive mode, the ramp generator is disabled and the VCO is controlled using the frequency control. This internally-generated signal is heterodyned against the received signal from a target pinger or marker beacon. The VCO is adjusted so that the beat frequency is a 1000-Hz tone, which is easily heard. In the passive mode, the operator has angular directional sensing only.

Other Functions

The sonar unit is equipped with a volume control that permits the operator to adjust headphone signal level in active or passive modes.

An electronic leak detector built into the unit facilitates pre-operational testing for salt water leakage into the sonar unit. The leak alarm is a fixed tone at a level that cannot be changed by the volume control. Water leakage results in an inoperative unit, which should be returned to Ultra Electronics Ocean Systems.

Functional Block Diagram

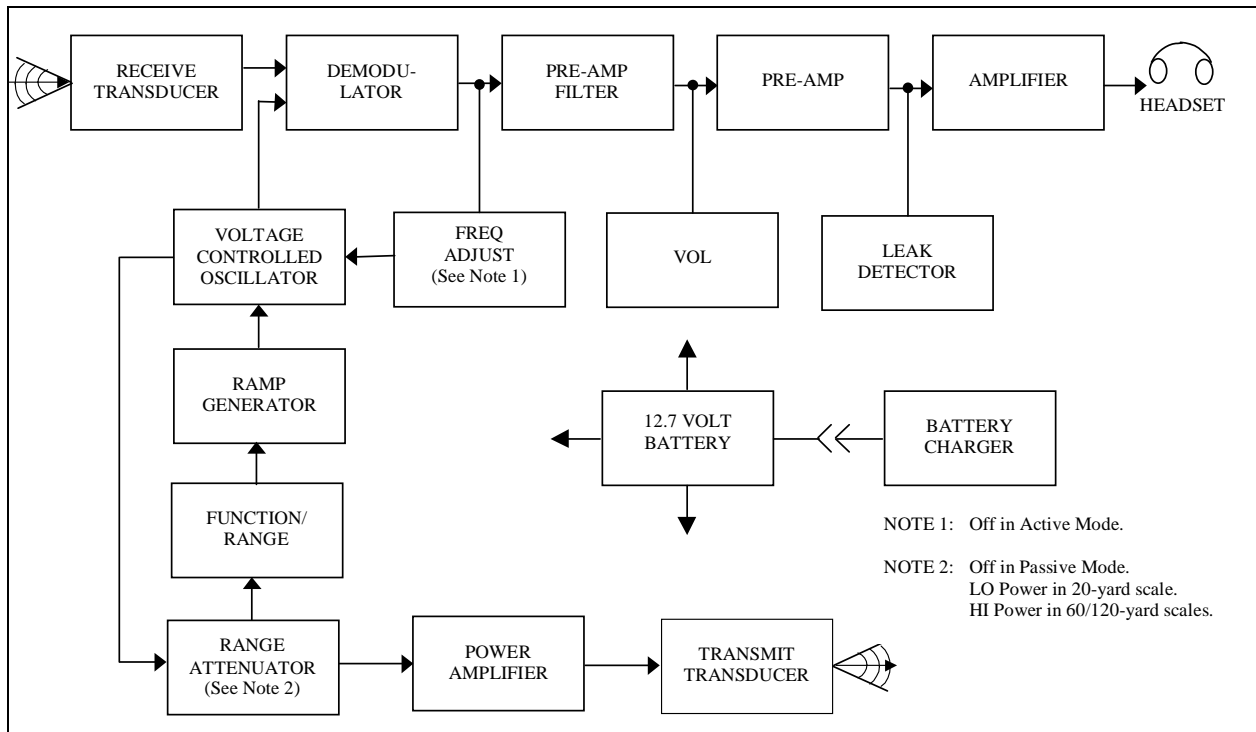

Figure 4 – DLS-2A Sonar Unit Functional Block Diagram

Accessories

Table 4 lists sonar set accessories, quantities, and manufacturers' part numbers. These accessories are contained in the carrying case.

Table 4 – Sonar Set Accessories

Description	Quantity	Part Number
Carrying Case	1	3200-1014-2
Compass	1	3200-1068
Flotation Collar	1	3200-5033-2
Battery Charger	1	3200-1039
Headset	1	3200-5030
Skull Cap	1	3200-1033
Lubricant	1	3200-5035

Figure 5 - Sonar Set Accessories



Index

A

accessories, sonar set · 17
active mode
 operating the sonar unit in · 9
 overview · 4
 reference data · 4
 theory of operation · 15
air test · 10

B

batteries
 charging · 13
battery charger
 description · 6
 part number · 17
battery check · 10
block diagram, DLS-2A · 15, 16

C

carrying case
 description · 6
 part number · 17
cautions
 list · 2
changes
 to manual · 1
 to product · 1
compass
 description · 6
 part number · 17
components
 function · 5
 photographs of · 5
 sonar unit · 7
controls
 sonar unit · 8

D

DLS-2A
 functional block diagram · 15, 16

F

flotation collar

 description · 6
 part number · 17
FREQ ADJ control
 function · 8
FUNCTION control
 function · 8
Function Select switch
 function · 8
functional block diagram, DLS-2A · 15, 16

H

headset
 description · 6
 part number · 17

I

indicators
 sonar unit · 8

L

leak detector · 16
liability · 1
lubricant
 description · 6
 part number · 17

M

maintenance
 corrective · 13
 preventative · 13
 scheduled · 14
manual
 requesting additional copies · 1
modes of operation
 overview · 4
 reference data · 4
 theory · 15
Mu, low
 recertification for · 14

O

operating procedures
 air test · 10
 battery check · 10

charging the batteries · 13
post-operation · 12
pre-deployment check · 11
visual check · 10
operation
theory of · 15
operational readiness check
air test · 10
battery check · 10
visual check · 10
O-ring lubricant
description · 6

P

part numbers, sonar set · 17
passive mode
operating the sonar unit in · 9
overview · 4
reference data · 4
theory of operation · 15
post-operation
procedures · 12
pre-deployment check
procedure · 11
troubleshooting · 12
procedures
air test · 10
battery check · 10
charging the batteries · 13
post-operation · 12
pre-deployment check · 11
visual check · 10
product
changes · 1
liability · 1
warranty · 1

R

recertification · 14
reference data
active mode · 4
passive mode · 4
sonar unit · 7

S

safety precautions · 2
scheduled maintenance · 14
skull cap
description · 6
part number · 17
sonar set
accessories · 17
function of components · 5
functional block diagram · 15, 16
overview · 3
photographs of components · 5
sonar unit
components · 7
controls and indicators · 8
description · 6
functional characteristics · 7
operating in active mode · 9
operating in passive mode · 9
overview · 3
physical characteristics · 7

T

theory of operation · 15
troubleshooting
post-operation · 13
pre-deployment check · 12

V

visual check · 10
VOL control
function · 8
volume control
operation · 16

W

warranty · 1
water leakage, detection · 16